

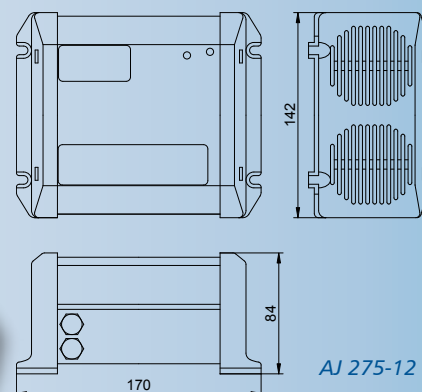

Sine Wave Inverter

Power class 275 - 2400 W

Steca AJ

275-12, 350-24, 400-48, 500-12, 600-24, 700-48, 1000-12, 1300-24, 2100-12, 2400-24

A particular feature of the AJ inverter series is its wide range of available power classes and DC input voltages, enabling the optimal inverter to be used for any application. The cables for the battery and load connection are already pre-mounted on the AJ, thus making it easier to connect the device. The automatic standby mode considerably reduces the inverter's self consumption. The AJ inverter's excellent overload capacity ensures that even critical loads can be operated easily.

Options

- types with 115 V / 50 Hz, 115 V / 60 Hz or 230 V / 60 Hz
- terminal for connecting of a remote control (On / Off) for the types AJ275-12 to AJ700-48
- remote Control JT8 (On / Off, LED) for AJ1000-12 to AJ2400-24

Features

- power range 275 - 2,400 W
- suitable for all AC loads
- excellent overload capabilities
- adjustable, automatic load detection
- best reliability

Electronic Protections

- battery deep discharge protection
- battery over voltage shut down
- over temperature and over load protection
- short circuit protection
- reverse polarity protection by internal fuse (other than AJ2100-12)
- acoustic warning before battery low or overheating disconnection

Displays

- operational status inverter by LED



Inverter AJ	275-12	350-24	400-48	500-12	600-24	700-48	1000-12	1300-24	2100-12	2400-24
nominal input voltage (V)	12	24	48	12	24	48	12	24	12	24
input voltage range (V)	10.5 - 16	21 - 32	42 - 64	10.5 - 16	21 - 32	42 - 64	10.5 - 16	21 - 32	10.5 - 16	21 - 32
output voltage	230 V +0 / -10 % (true sine wave)									
output frequency	50 Hz +/-0.05 %									
continuous power (VA)	200	300	300	400	500	500	800	1000	2000	2000
max. power 30 min. (VA)	275	350	400	500	600	700	1000	1300	2100	2400
max. power 5 sec. (VA)	450	650	1000	1000	1200	1400	2200	2800	5000	5200
maximum efficiency (%)	93	94	94	93	94	94	93	94	92	94
consumption Stand-by (W)	0.3	0.3	0.4	0.3	0.4	1.0	0.3	0.4	0.5	0.4
load detection (Stand-by)	2 W			adjustable: 1 - 20 W						
cable length Battery / AC	1.2 m / 1 m			1.5 m / 1 m				1.7 m / 1 m		
operating temperature	-20 °C to +50 °C									
protection class	IP 30									IP 20
weight (kg)	2.4	2.6		4.5			8.5		19	18
dimensions l x w x h (mm)	170 x 142 x 84			247 x 142 x 84			455 x 142 x 84		406 x 273 x 117	

Technical data at 25 °C / 77 °F